



QUIZ 1

16 January 2015
Doç. Dr. M. Ali Güler

Ad, Soyad: **SOLUTION**
No: _____

Problem: The shaft is supported at its ends by two bearings A and B. The shaft is also subjected to the forces applied to the pulleys fixed to the shaft. Determine the resultant internal loadings acting on the cross section located at point C. The 300N forces act in the $-z$ direction and the 500N forces act in the $+x$ direction. The journal bearings at A and B exert only x and z components of force on the shaft.

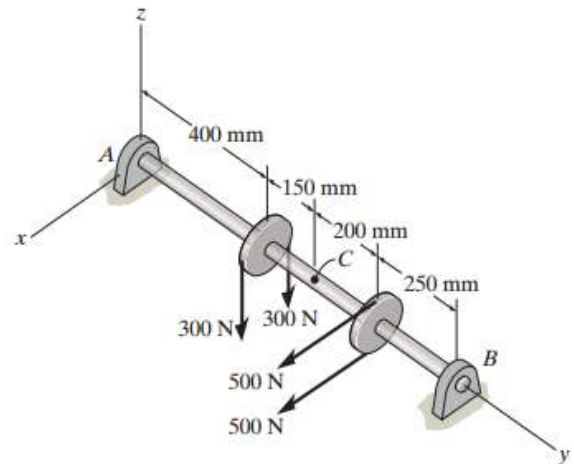

Reference: Hibbeler, 8th Ed./1-26

$$\Sigma F_x = 0; \quad (V_C)_x + 1000 - 750 = 0; \quad (V_C)_x = -250 \text{ N}$$

$$\Sigma F_y = 0; \quad (N_C)_y = 0$$

$$\Sigma F_z = 0; \quad (V_C)_z + 240 = 0; \quad (V_C)_z = -240 \text{ N}$$

$$\Sigma M_x = 0; \quad (M_C)_x + 240(0.45) = 0; \quad (M_C)_x = -108 \text{ N} \cdot \text{m}$$

$$\Sigma M_y = 0; \quad (T_C)_y = 0$$

$$\Sigma M_z = 0; \quad (M_C)_z - 1000(0.2) + 750(0.45) = 0; \quad (M_C)_z = -138 \text{ N} \cdot \text{m}$$

